

Operator Manual
For use with WFCO ULTRA III Deckmount Converter
WF-9800 Series
(model number located on the cover of the unit)

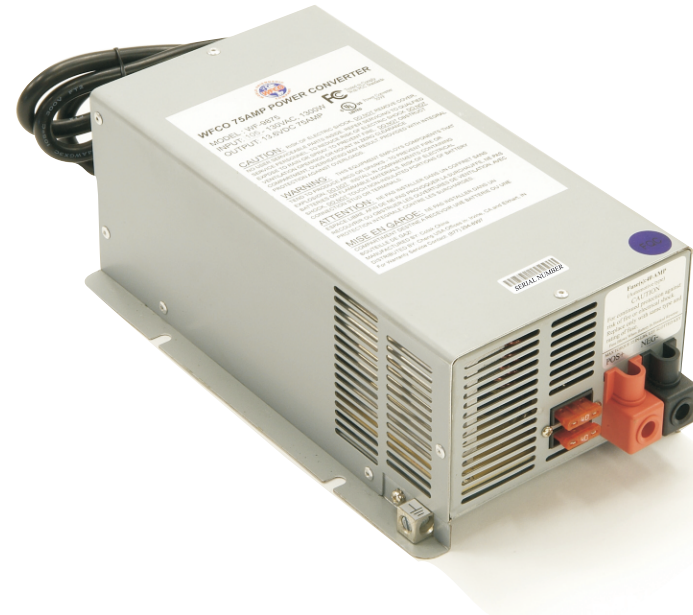

Distributed in the U.S.A. and Canada by
ARTERRA DISTRIBUTION
Warranty Service (877) 294-8997
Fax (574) 294-8698
www.wfcoelectronics.com

Installation and Servicing of the WFCO WF-9800 Series Power Center

⚠ CAUTION ⚠

This product should be installed by an experienced technician. CAUTION and care must be taken when servicing this equipment. To prevent severe shock or electrocution consult your servicing dealer. No serviceable parts.

⚠ WARNING ⚠

This unit employs components that tend to produce arcs or sparks. To prevent fire or explosion, do not install in compartments containing batteries or flammable materials (LP gas).

⚠ CAUTION ⚠

To prevent fire, do not cover or obstruct ventilation openings. Do not mount in zero-clearance compartment. Overheating may result. For continued protection against risk of fire, or electric shock replace only with same type and ratings of fuse.

⚠ CAUTION ⚠

Check on a monthly basis the fluid level in any battery connected to RV charging system.

This product is not ignition protected and should not be installed in an LP compartment.



General Consumer Information

- **Reverse Battery Protection**
This feature prevents permanent damage to the converter from an incorrect battery connection.
- **Automatic Cooling Fan**
The fan is variable speed and current controlled.
- **Electronic Current Limiting**
Automatically shuts down power during overload or short-circuit conditions. Automatically returns to normal operation after conditions are corrected.
- **DC Fuses**
Reverse battery protection fuses; replace with ATC "Littelfuse®" Type 257 fuse.
- **Lightweight**
 - 35 A unit weighs only 9.03 lbs.
 - 45 A unit weighs only 11.20 lbs.
 - 55 A unit weighs only 11.57 lbs.
 - 65 A unit weighs only 14.33 lbs.
 - 75 A unit weighs only 14.88 lbs.

INSTALLATION INSTRUCTIONS

3

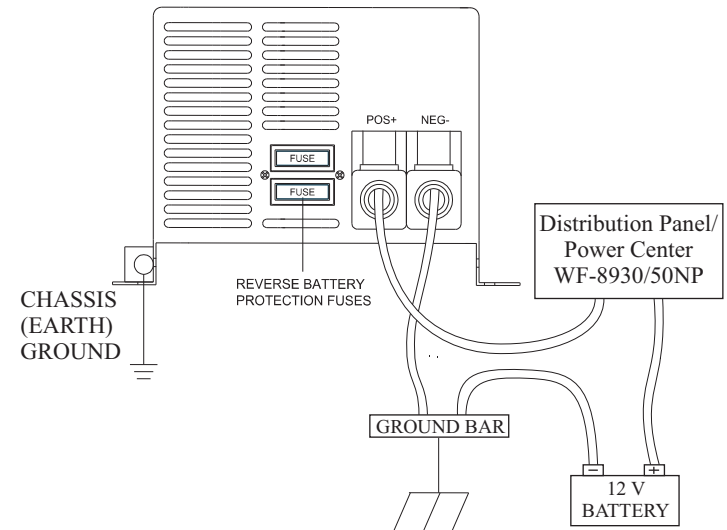



Converter Operation Modes

All WFCO power converters are automatic three-stage switching power supplies. The converter senses which mode it needs to be in by checking the RV system voltage.

The three modes/stages of operation include:

Absorption mode/Normal operation

Nominal battery charge and supplies power to appliances

Bulk mode/Charge mode

Fast battery charge and supplies power to appliances

Float mode/Trickle charge

Trickle battery charge during storage

Absorption Mode: During this mode, the converter output is in the 13.6 Vdc range. This is the normal operation mode. This mode provides the 12 Vdc and current required by the 12 Vdc RV appliances, as well as slow charging the battery.

Bulk Mode: In this mode, the output voltage of the converter will switch to 14.4 Vdc for a maximum of four hours. If the converter cycles between “Absorption and Bulk mode,” there could be a shorted battery cell or other issues.

Float Mode: In this mode, the converter is charging the battery with a trickle voltage of 13.2 Vdc. When the converter senses a demand (by turning on lights), the converter automatically returns to the “Absorption mode”.

OPERATIONAL FEATURES

6



Troubleshooting WF-9800 Series Converter

If the input from shore power is 105 Vac-130 Vac to the receptacle, check the reverse battery protection fuse on the front plate of the WF-9800 deckmount converter. Visually inspect the fuses for any breaks/opens. If the fuses do not appear to be open, use a tester to check for continuity.

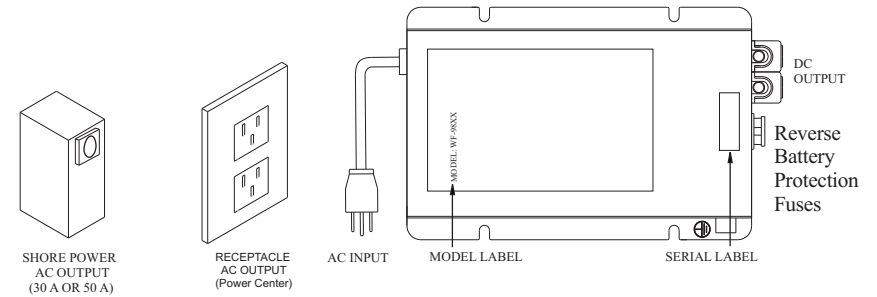

If the reverse polarity fuses are blown, it means the RV battery was accidentally connected in reverse, either at the battery or at the converter. Reconnect properly, then replace the fuse with the same type and amp rating as the original “Littelfuse®” Type 257 automotive-style fuse.

IMPORTANT: These fuses protect the converter from damage in the event that the RV battery is accidentally connected in reverse. A reverse battery connection, even for a second, is the only reason that these fuses will blow.

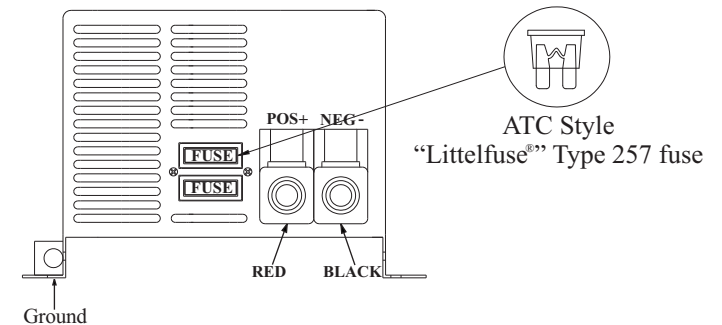

7 TROUBLESHOOTING INSTRUCTIONS



WF-9800 Series Troubleshooting

Before checking the converter output voltage, it is necessary to disconnect the battery cables at the battery. Make sure the converter is plugged into AC source (105-132 Volts). Check the converter output voltage at the battery with a voltmeter. Place the probes on the disconnected battery cables; place the **Positive** (red) meter probe on the + positive red battery wire and place the **Negative** (black) meter probe on the **-Negative** black wire on the battery cable. Be sure you have good connections at the cables. If the voltage reads 13.6 Vdc (+/- .2) with no load, the converter is functioning properly.

Nominal setup for WF-9800 Series

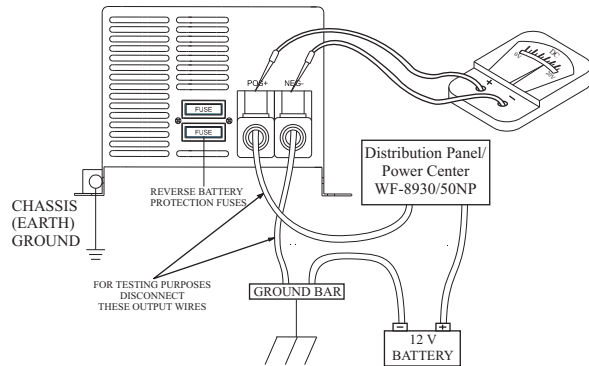

If the converter output voltage at the battery reads in the 0.0 Vdc range, or the battery is not charging, check for:

- an open inline fuse in the battery wire (if installed by OEM)
- an open wire between the converter and the RV battery
- loose ground connection
- improper torques

If the converter fuses and AC voltage are good, but the converter output still reads zero volts, the converter is not functioning properly.

Contact WFCO Tech Support at (877) 294-8997.

TROUBLESHOOTING INSTRUCTIONS 8



GENERAL COMPLIANCE INFORMATION

The WF-9800 Series units are UL[®]-Listed, and cUL[®]-Listed (Canadian). They comply with FCC Class B requirement (see below)

FCC Compliance Class B

NOTE: This equipment has been tested and found to comply with the limits for a Class B digital device, pursuant to Part 15 of the FCC Rules. These limits are designed to provide reasonable protection against harmful interference when the equipment is operated in a commercial environment. This equipment generates, uses, and can radiate radio frequency energy and, if not installed and used in accordance with the instruction manual, may cause harmful interference to radio communications. Operation of this equipment in a residential area is likely to cause harmful interference in which case the user will be required to correct the interference at his own expense.

COMPLIANCE 9



**Consumer Limited Warranty
For
WFCO Electronic Products**

WFCO extends to the original owner a Two-Year Limited Product Warranty. This Warranty is in effect from the date of original purchase for a period of two (2) years. This Limited Warranty is extended specifically for and is limited to recreational vehicle application and is valid only within the continental United States, Alaska, Hawaii and the provinces of Canada. WFCO warrants to the owner that its products are free from defects in material and workmanship under normal use and service, based on its intended use and function. This Warranty is limited to the repair or replacement, at WFCO's discretion, of any defective parts or defective assembly. Any implied warranties of merchantability or fitness for intended use are limited in duration unless applicable State Law provides otherwise. You may have other rights as specified by each individual state.

EXCLUSIONS and LIMITATIONS

The OEM Warranty specifically does not apply to the following:

Any WFCO product that has been repaired or altered by any unauthorized person. Any damage caused by misuse, faulty installation, testing, negligence or accident or any WFCO product installed in a commercial vehicle.

Any WFCO product whose serial number has been defaced, altered or removed. Any WFCO product whose installation has not been in accordance with the WFCO written instruction. Any consequential damages arising from the loss of use of the product including, but not limited to, inconvenience, loss of service, loss of revenue, loss or damage to personal property and cost of all services performed in removing or replacing the WFCO product. Specifications are subject to change without notice or obligation.

CONSUMER WARRANTY CLAIM PROCEDURE

Upon determination and validation by an authorized OEM dealer that a WFCO product has a defect, a Return Goods Authorization (RGA) number will be required before it can be returned. The RGA number can be requested by completing the **Warranty Information Fax Sheet** found at www.wfcoelectronics.com. Once the form has been completed, email this form along with Proof of Purchase to warranty@wfcoelectronics.com or fax both forms to the Warranty Department at (574) 294-8698. After receipt of the forms, an RGA number will be issued. This number shall appear on all correspondence with warranty service. Upon validation of the warranty, WFCO shall replace or repair the product with a like product. The RGA number shall be placed on the outside of the carton used to return the product, for ease of identification. Do not mark directly on the product. The product must be packaged properly to avoid further damage to the product, which could cause a non-warrantable condition.

LIMITED WARRANTY

10